

Installation Step

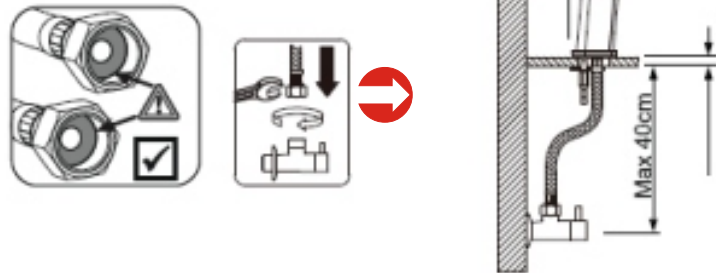

Installation Fig

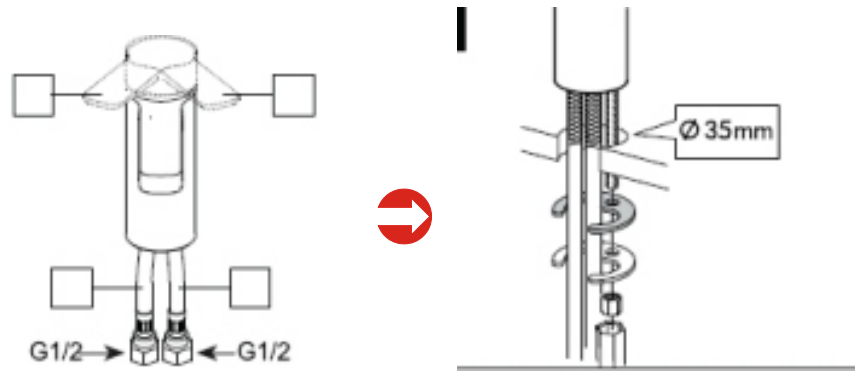
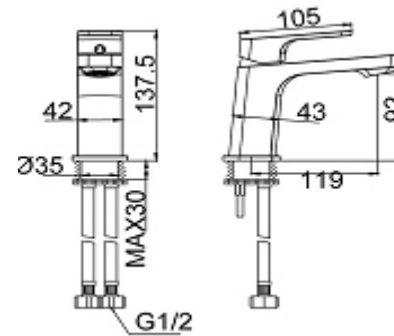

Flow rate Curves

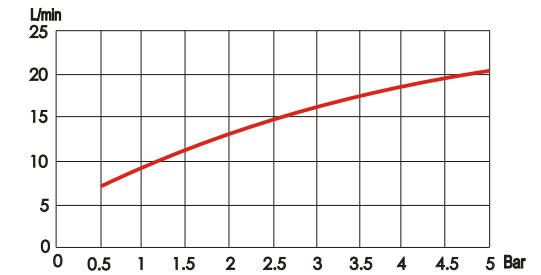

Test pressure: 1.6MPa (16bar)

Flow pressure:

Min 0.05MPa

Max 1.60MPa

Recommended pressure:

0.1MPa to 0.8MPa (1 to 8 bar)

Note

- 1.Ensure to clean the water supply pipe before installing to avoid being jammed.
- 2.The cold-water supply must be connected on the right and the hot-water supply on the left.
- 3.Check the installing dimension according to the Figure and ensure it is installed correctly.
- 4.Hot-water inlet must not be over 80 C.°