

Installation Step

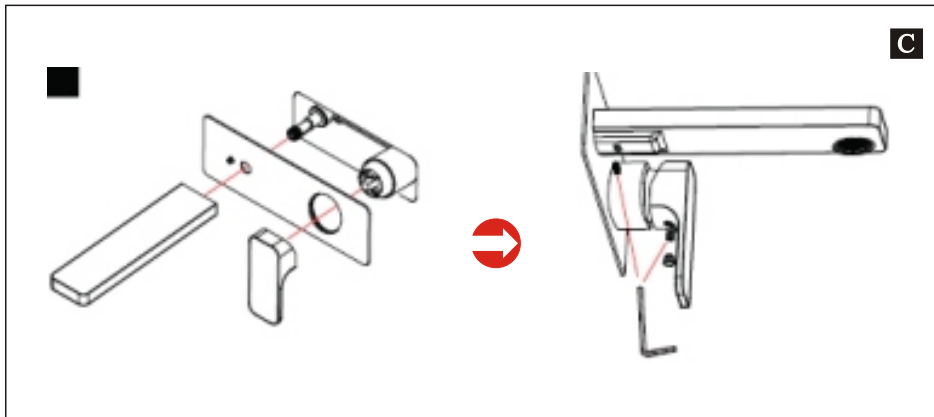
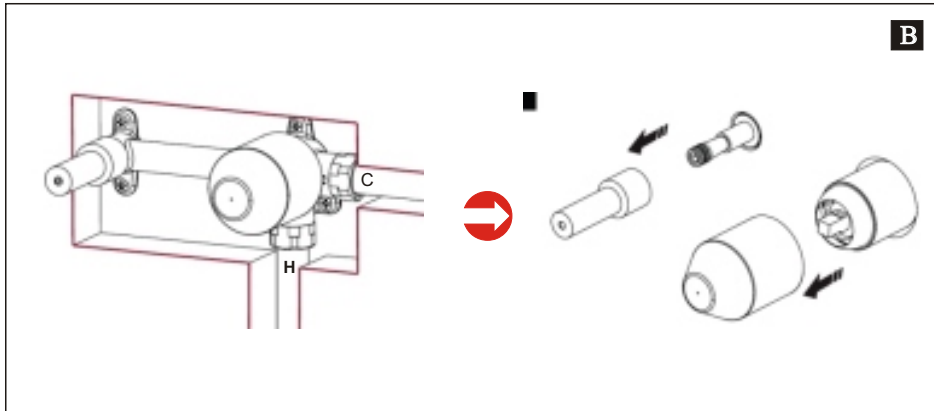
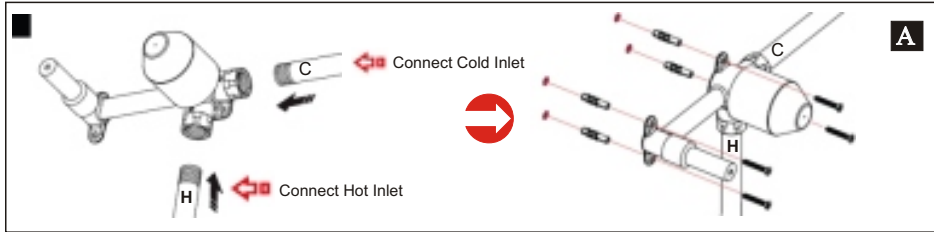

✱ See the fig for the position of the valve and inlet pipes.

✱✱ Test:

Open the supply pipes, close the ceramic cartridge and check any leakage; open the ceramic cartridge and check the smooth water flow. Having tested, install the valve to the wall, take the safe cover apart and install the plate and handle.

Installation Fig

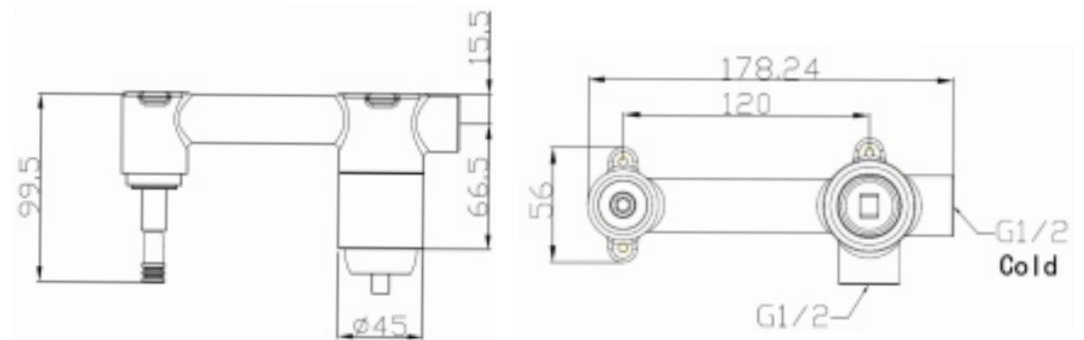

Flow rate Curves

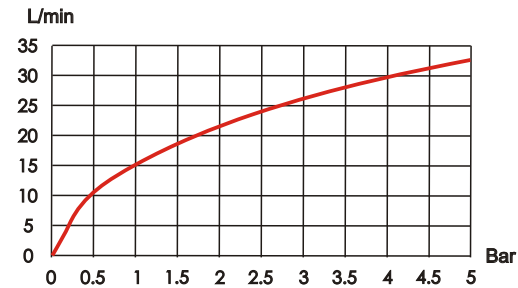

Test pressure: 1.6MPa (16bar)

Flow pressure:

Min 0.05MPa

Max 1.60MPa

Recommended pressure:

0.1MPa to 0.8MPa (1 to 8 bar)

Note

- 1.Ensure to clean the water supply pipe before installing to avoid being jammed.
- 2.The cold-water supply must be connected on the right and the hot-water supply on the left.
- 3.Check the installing dimension according to the Figure and ensure it is installed correctly.
- 4.Hot-water inlet must not be over 80 C.°